

Specifications

Model	GTH™ -2506	
Measurements	Metric	Imperial
Lifting height maximum	5.79 m	19 ft
Lifting capacity maximum	2,500 kg	5,511 lbs
Lift capacity at maximum height	2,000 kg	4,409 lbs
Lift capacity at maximum reach	900 kg	1,984 lbs
Forward reach maximum	3.33 m	10 ft 11 in
Reach at maximum height	60 cm	2 ft
A Height	2.16 m	7 ft 1 in
B Height at steering wheel	1.25 m	4 ft 1 in
C Width	1.81 m	5 ft 11 in
D Cab width	86 cm	2 ft 10 in
E Track	1.5 m	4 ft 11 in
F Wheelbase	2.36 m	7 ft 9 in
G Length at front wheels	3.35 m	11 ft
H Length at fork-holder plate	3.84 m	12 ft 7 in
I Ground clearance	33 cm	1 ft 1 in
J Overall length	5.04 m	16 ft 6.5 in
M1 Obstruction angle		90°
M2 Departure angle		60°

Measurements

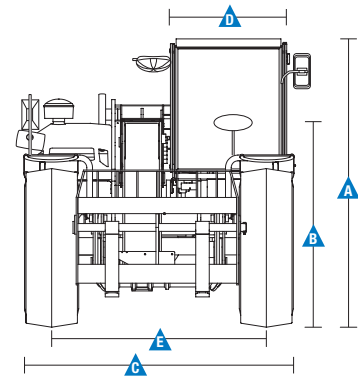
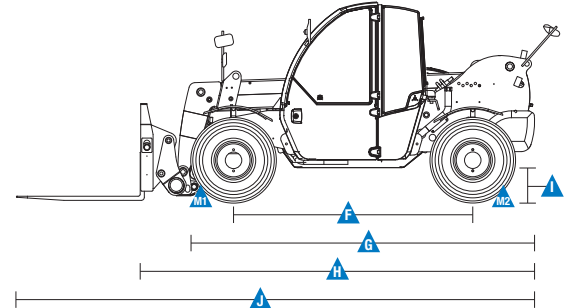

Productivity

Inside/outside turning radius	1.6 m/4 m	5 ft 3 in/13 ft 1 in
Break-out force*	3,700 kg	8,157 lbs
Towing capacity at dynamometer**	3,100 kg	6,834 lbs
Drive speed max.	23 km/h	14 mph
Fork-holder plate rotation		130°
Tyres (DIN 70361)	12-16.5" PR10 8 hole wheel rim	
Lifting/lowering speed**	8 sec./7.5 sec.	
Extension/retraction speed**	8 sec./6 sec.	

Power

Engine	Deutz TD 2.9 L4, 4-cylinder diesel 74 hp (55.4 kW), stage IIIA	
Transmission	Hydrostatic variable displacement pump linked to variable displacement motor. Both piston type.	
Function pump	Boom & Control system gear pump type: 280 Bar, 70 L/min.	
Fuel tank capacity	60 L	15.9 gal
Engine oil capacity	10 L	2.6 gal
Hydraulic oil tank capacity	65 L	17.2 gal

Weight***	5,420 kg	11,948 lbs
-----------	----------	------------

Standards Compliance

AS 1418.19
Operating cab conforms to ISO3471 (ROPS) and ISO3449 (FOPS)

GTH-2506 AU.3
LOAD CHART WITH FORKS

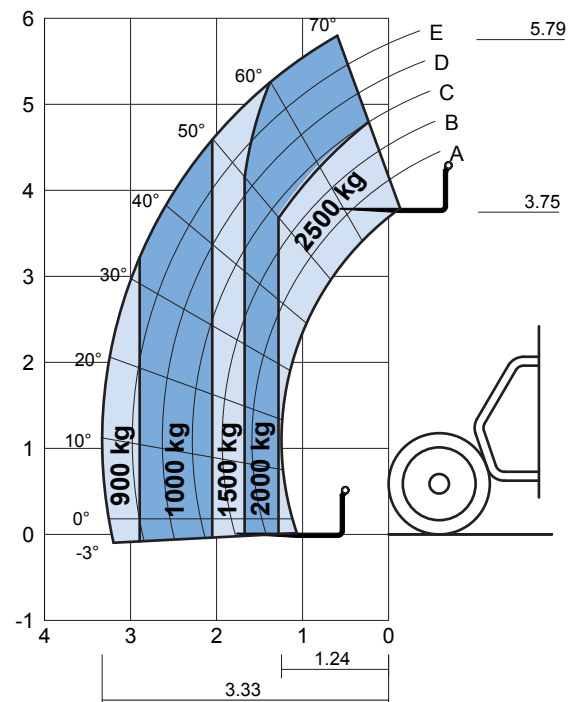

* With 800 L shovel SAE J 732/80
** Without load
*** Weight will vary depending on options and/or country standards

Features

Standard Features

Measurements

- 2,500 kg (5,511 lb) maximum lift capacity
- 5.79 m (19 ft) maximum lift height
- 3.35 m (10 ft 12 in) maximum forward reach

Productivity

- 4WD
- Four wheel steer
- 3 steering modes:
 - front wheel steer
 - crab steer
 - coordinated steer
- Hydraulic line on boom
- Power assisted steering
- Hydrostatic transmission with variable displacement pump and motor
- Electro-proportional 4x1 joystick
- Limited slip differential on front axle
- Two-section door (glass upper/steel lower)
- Angle and length indicators on boom correspond to load charts
- Adjustable suspended seat with operator detection seat contact switch
- Battery disconnection switch
- Large diameter steering wheel
- Front & rear windscreen wipers
- Sunshield
- Roof protection grid
- Two side view mirrors and rear fish eye mirror
- Front & rear lights
- Side mounted engine for easy access to components
- Oil immersed, multi-disc brakes on front axle
- Self activated parking brake hydraulically released
- Lockable fuel tank
- Maintenance collar
- Road/jobsite switch
- Air conditioning
- Additional hydraulic line on boom

- Load Management System (LMS) with:
 - Dynamic colour coded load chart
 - 7" colour display
 - Reversing camera
 - Optional front camera
 - Optional iButton user access control
- Hydraulic quick coupling for attachments
- Windshield protection grid

Power

- Deutz diesel 74 hp (55.4 kW), stage IIIA

Tyres

- 12-16.5" PR10, 8 hole wheel rim (DIN 70361)

Options & Accessories

Productivity

- Adjustable spotlight on boom and cabin
- Biodegradable hydraulic oil

Attachments

- Genie has a large range of attachments available. Please contact Genie or your nearest Genie telehandler dealer.



Genie – Toll free number 1800 788 633

Brisbane

HEAD OFFICE
33 Kimberley Street
Darra QLD 4076

Sydney

74 Glendenning Road
Glendenning NSW 2761

Melbourne

374 Hammond Road
Dandenong VIC 3175

Adelaide

16-18 Nixon Road
Wingfield SA 5013

Perth

126 Sheffield Road
Welshpool WA 6106

Darwin

33 McCourt Road
Yarrawonga NT 0830

Genie USA

18340 NE 76th Street
P.O. Box 97030
Redmond, Washington
98073-9730

Distributed By:

Effective Date: December, 2015. Product specifications and prices are subject to change without notice or obligation. The photographs and/or drawings in this document are for illustrative purposes only. Refer to the appropriate Operator's Manual for instructions on the proper use of this equipment. Failure to follow the appropriate Operator's Manual when using our equipment or to otherwise act irresponsibly may result in serious injury or death. The only warranty applicable to our equipment is the standard written warranty applicable to the particular product and sale and we make no other warranty, express or implied. Products and services listed may be trademarks, service marks or trade names of Terex Corporation and/or their subsidiaries in the USA and many other countries. Genie is a registered trademark of Terex South Dakota, Inc. © 2015 Terex Corporation.